



Designer Shingle Installation Instructions



Directions for Applying Malarkey Windsor® Designer Shingles

GENERAL INSTRUCTIONS

Install Malarkey Windsor® designer shingles in accordance with adopted building code and local amendments. To qualify for warranty protection and obtain stated coverage, the installation instructions detailed here must be followed. Contact Malarkey Technical Services or check our website at WWW.MALARKEYROOFING.COM for the most current version.

We assume no responsibility when there has been improper application, failure to properly prepare the surface or provide adequate ventilation according to FHA or HUD minimum property standard requirements and adopted building code.

For current warranty information, please visit: WWW.MALARKEYROOFING.COM/warranties.

Standard exposure is 5¾" (146 mm) to the weather. Offset between courses is 6⅞" (162 mm). Minimum offset for shingle installation is 5½" (140 mm).

These step-by-step application instructions apply to standard slopes/inclines not less than 4" (102 mm) per 12" (305 mm) or more than 21" (533 mm) per 12" (305 mm). For low slopes [2" (51 mm) to less than 4" (102 mm) per 12" (305 mm)] and steep slopes [more than 21" (533 mm) per 12" (305 mm)], modify the installation as described below. Do not apply shingles on roofs having a slope less than 2" (51 mm) per 12" (305 mm).

Note: The film strip on each shingle is to prevent the shingles from sticking together while in the bundle and is not designed to be removed.

IMPORTANT

- ALWAYS wear fall protection when working on a roof.
- Underlayments can be slippery, particularly when wet or covered with frost. Be careful when walking on them.

Ventilation: To prevent harmful condensation or heat buildup, air must circulate freely under the roof deck. Install roof vents at ridges and eaves. Ventilation provisions must meet or exceed current FHA or HUD requirements and adopted building codes.

Roof Deck: The surface to receive the new roofing should be in good condition and solidly sheathed, constructed of a minimum ⅝" (10 mm) thick, exterior-grade plywood, 7/16" (11 mm) oriented strand board (OSB), or seasoned lumber, nominally 1" (25 mm) thick. Boards should be positioned tight to each other and securely nailed to framing members. Replace deteriorated or rotted boards, and for excessively resinous areas and loose knots, cover with sheet metal patches.

Malarkey strongly recommends installing sheathing when wood board decking is the existing substrate. Problems with the performance of your roofing system, such as leaks and buckling, increase if installed directly over wood board decks. Failure to use properly conditioned deck materials can result in deck movement which can damage the roof covering and may void your warranty.

Drip Edge Flashing: In accordance with current International Building Code, Section 1507.2.8.3, and International Residential (Building) Code, Section R905.2.8.5, *drip edge flashing* (drip edge, eave or rake metal) is required along the eave and rake edges of shingle roofs.

Install drip edge first along the eaves and later on the rakes once the field underlayment has been applied.

UNDERLAYMENT

Malarkey makes two types of underlayment, the first being water-resistant, *mechanically-attached* field underlayments Right Start® UDL and our Secure Start® line of synthetic underlayments.

The second type are waterproof, *self-adhering* underlayments, Arctic Seal® and Secure Start® HT products which are intended for use in cold weather climates that produce ice dams.

Self-adhering underlayment can also be installed as a flashing membrane in areas susceptible to leaks such as roof valleys, roof-to-vertical transitions, and around vents, curbs, skylights and other roof penetrations.

Underlayment is required on roof decks prior to the installation of Malarkey shingles. Your geographical location, weather, degree of roof slope, and type of roof covering will help determine which Malarkey underlayment is right for your situation. Consult local building code for additional guidance.

Complete installation instructions are available on our website at WWW.MALARKEYROOFING.COM.

Other Instructions Common to the Installations that Follow:

- Underlayment is installed parallel to the eaves.
- End laps in the same course should be 6" (152 mm), and staggered 6' (1.8 m) apart in subsequent courses.
- Extend field underlayments 6" (152 mm) over hips, ridges and valleys. Where the roof meets a vertical surface, run the underlayment a minimum of 3" (76 mm) up the wall and secure.
- Once an expanse of roof is covered by underlayment up to the ridge, apply drip edge flashing to the rakes, over the ends of underlayment.

INSTALLATION IN NON-ICE DAM REGIONS

Roof Slopes 4:12 and Greater

Roof slopes 4:12 (4" [102 mm] per 12" [305 mm]) and greater require the installation of a single (1) layer of Malarkey's field underlayment (or code-compliant equivalent) over the entire roof deck.

Install the initial course flush to the eave and trim at the rake. Fasten sufficiently to hold the underlayment in place and work safely until shingles are applied or according to adopted building code. Secure Start® underlayments have bullseye imprints on the material to act as guides for fastening.

Continue working up the roof, subsequent courses overlapping the preceding by 2"-4" (51-102 mm), depending on the type of underlayment being applied. (See Figure 1)

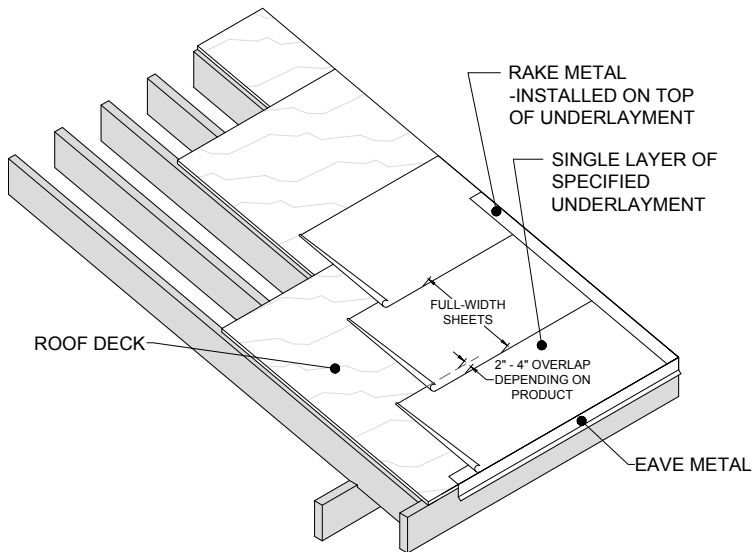

Figure 1 - Application of Field Underlayment on Roof Slopes 4:12 and Greater (Non-Ice Dam Regions)

Roof Slopes 2:12 Up to 4:12

Install a *double layer* of any Malarkey underlayments. If local building code has adopted 2015 or later IBC or IRC, a *single layer* of ASTM D1970 underlayment (Arctic Seal®, Secure Start® HT) is acceptable as an exception per the I-Codes.

For a double layer, start at a lower corner of roof and begin by applying a half-width *starter strip* of field underlayment (or code-compliant equivalent) along the eaves.

Succeeding courses are all full-width, the first course completely overlapping the starter, and followed by courses half-lapped over preceding courses.

Fasten sufficiently to hold in place and work safely until shingles are applied or according to adopted building code. (See Figure 2)

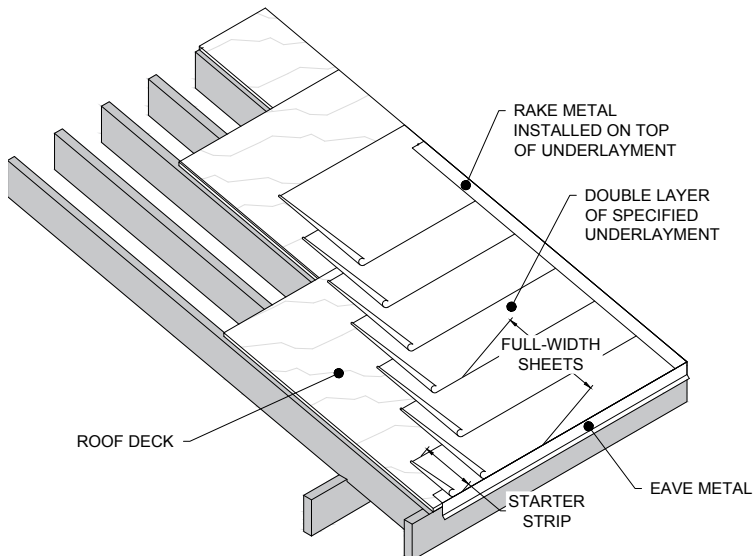

Figure 2 - Application of Field Underlayment on Roof Slopes 2:12 Up to 4:12 (Non-Ice Dam Regions)

Optional installation for low slope roofs: For superior protection in coastal regions, areas of wind-driven rain, or homes

with double-slope construction, the roof deck can be covered with a double layer of Arctic Seal® self-adhering underlayment or equivalent conforming to ASTM D1970.

When choosing this option, make sure proper ventilation and moisture control issues are addressed.

INSTALLATION IN ICE DAM REGIONS

Roof Slopes 4:12 and Greater

In geographic regions that experience the possibility of ice dams along the eaves (or if required by building code), install a full-width sheet of *self-adhering* underlayment (or equivalent underlayment conforming to ASTM D1970) along the eaves.

Continue installing self-adhering underlayment up and out onto the roof no less than 24" (610 mm) past the inside, warm interior wall of the house or above the expected level of ice dams or according to building code requirements.

If additional courses of self-adhering underlayment are necessary to reach that point, *course lap guide lines* (lay lines) on the sheets show how far to lap the material. Firmly hand-roll these overlaps to ensure a complete, watertight bond.

Once past 24" (610 mm), follow with full-width courses of your specified field underlayment, the first course lapped 6" (152 mm) over the termination of self-adhering underlayment and the rest with 2"-4" (51-102 mm) side laps, depending on the type of underlayment being applied. Lay lines show how far to lap the material.

Fasten as described above.

For extra protection at the eaves and prior to the installation of drip edge, install a 6"-wide (152 mm) stripping ply of Arctic Seal®, and ensure it covers the junction of roof and fascia.

(See Figure 3)

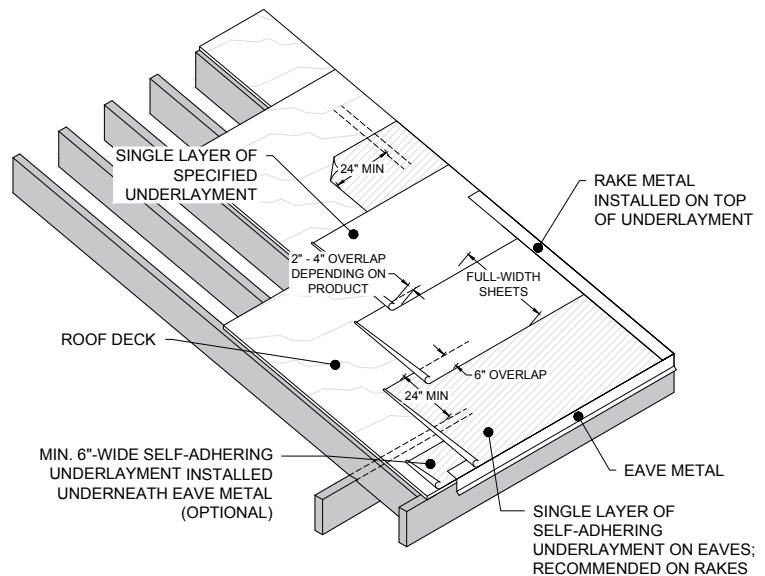

Figure 3 - Application of Self-Adhering and Field Underlayments on Roof Slopes 4:12 and Greater (Ice Dam Regions)

Roof Slopes 2:12 Up to 4:12

Like 4:12 and greater slopes, begin with a full-width sheet of self-adhering underlayment (or equivalent compliant with ASTM D1970) and apply along the eaves.

Continue application up and out onto the roof as necessary to a point not less than 24" (610 mm) past the inside, warm interior wall of the house or above the expected level of ice dams or according to building code requirements.

Once that point is reached, switch to *double layers* of your specified field underlayment, the first course a half-width *starter strip* lapped 6" (152 mm) over the termination of self-adhering underlayment.

Succeeding courses are full-width, the first course completely overlapping the starter, and followed by courses half-lapped over preceding courses, on up the roof.

Fasten as described above. (See Figure 4)

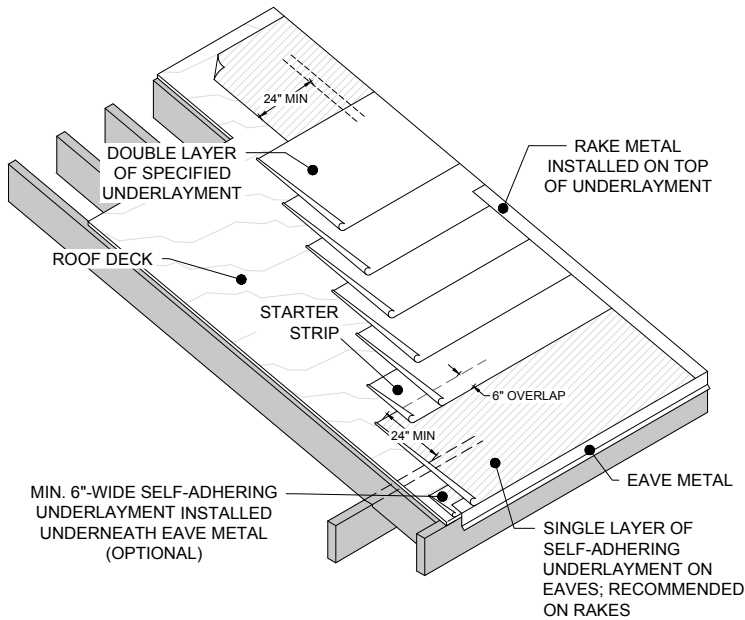

Figure 4 - Application of Self-Adhering and Field Underlayments on Roof Slopes 2:12 Up to 4:12 (Ice Dam Regions)

SHINGLE FASTENING

Type of Fasteners: Fasteners must be minimum 12-gauge (0.105 inch [3 mm]) shank, galvanized steel, stainless steel, aluminum or copper roofing nails, with a $\frac{3}{8}$ " (10 mm) head, compliant with ASTM F1667, and long enough to penetrate through all layers of roofing materials and at least $\frac{3}{4}$ " (19 mm) into the roof sheathing. Where the roof sheathing is less than $\frac{3}{4}$ " (19 mm) thick, the fasteners shall penetrate through the sheathing.

Malarkey approves the use of hand-nailing and/or pneumatic nailers for applying fasteners, but nails must be driven flush to the shingle surface and not overdriven, underdriven or driven at an angle, especially on low slope installations where water runs off less freely and leaks could result. When fastening adjacent shingles, butt them loosely together to prevent buckling.

The use of staples is not an approved fastening method. (See Figure 5)

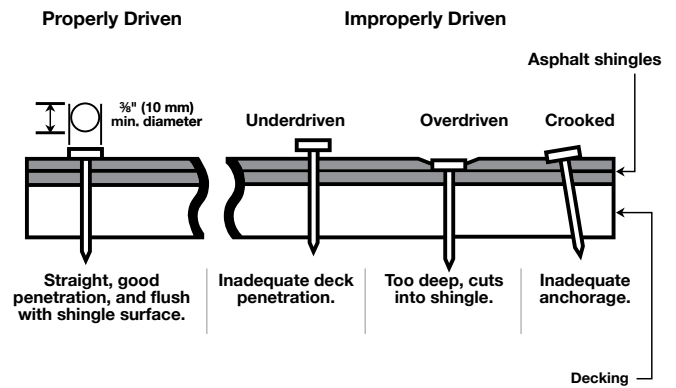

Figure 5 - Nailing Instructions

Nailing Pattern: Use five (5) fasteners for each shingle, evenly spaced across the shingle, and placed within the *high nailing area* designated by the parallel *nailing lines*. Ensure the outside fasteners are approximately 1" (25 mm) from each edge. (See Figure 6)

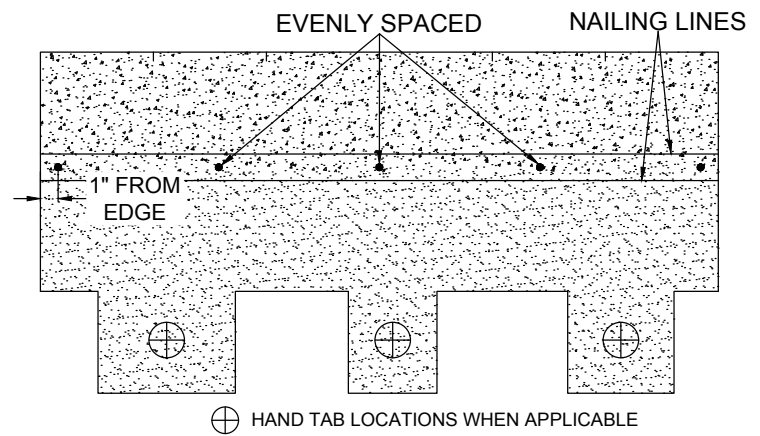

Figure 6 - 5-Nail Fastening Pattern and Hand-Tab Locations

In regions requiring six (6) nails per shingle, two methods can be used:

Method 1: Place four (4) fasteners in the high nailing area, evenly spaced across the shingle, with the outer fasteners 1" (25 mm) from each edge.

Place two (2) fasteners in the *low nailing area*, no more than 1" (25 mm) from each edge, and approximately $\frac{3}{4}$ " (19 mm) above the tabs, making sure they will be covered by shingle tabs in the course above them. (See Figure 7)

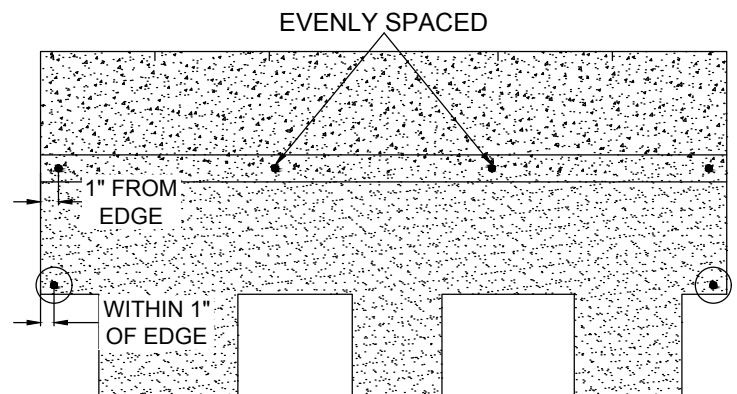

Figure 7 - 6-Nail Fastening Pattern

Method 2: Place two (2) fasteners in the high nailing area, each 1" (25 mm) from the outside edge.

Place four (4) fasteners in the low nailing area, approximately $\frac{3}{4}$ " (19 mm) above the tabs, making sure they will be covered by shingle tabs in the course above them.

The two inner notches, or slits*, at the top of the shingle will aid in the alignment of the two middle fasteners while the two outer fasteners are placed 1" (25 mm) from each edge. (See **Figure 8**)

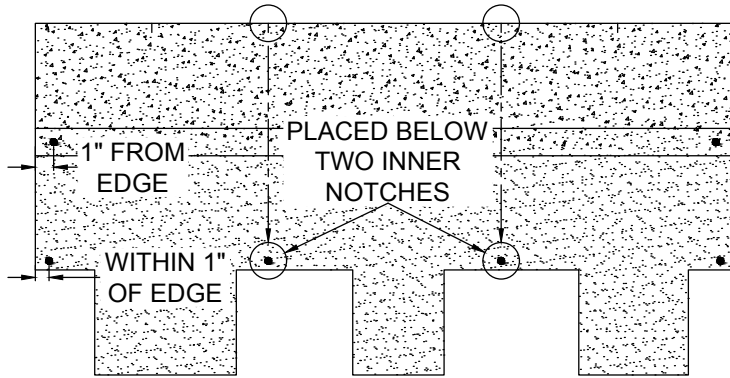

Figure 8 - Alternate 6-Nail Fastening Pattern

Wind Resistance and Hand-Sealing: Malarkey shingles are manufactured with strips of a factory-applied thermal sealant that is activated by the heat of the sun after the shingle is on the roof. Exposure to the sun and warm temperatures bonds each shingle to the one below for wind resistance.

A variety of conditions like cold weather, high winds or blowing dust, however, can affect the ability of the sealant strip to activate and prevent shingles from self-sealing during, or shortly after, installation.

If shingles have not sealed after a reasonable time period, *hand-sealing* (also called hand-tabbing) is strongly recommended.

Note: Malarkey's wind warranties apply only when shingles are sealed, whether by hand-sealing or activation of the self-sealing strips.

Failure to seal under adverse circumstances like those described above is not a manufacturing defect.

To hand-seal a Windsor® designer shingle, apply a quarter-size dab of asphalt roof cement conforming to ASTM D4586 under each shingle tab, and press them firmly into the cement (see Figure 6).

Excessive use may cause blistering; correct amounts should not bleed out from under the shingle.

Step Slope Fastening of Shingles: Roof decks with slopes greater than 21" (533 mm) per 12" (305 mm) require installation with nine (9) fasteners per shingle (six [6] for starter shingles) and hand-sealing of tabs.

Place five (5) fasteners in the high nailing area, evenly spaced across the shingle, with the outer fasteners 1" (25 mm) from each edge.

Place four (4) fasteners in the low nailing area, approximately $\frac{3}{4}$ " (19 mm) above the tabs, making sure they will be covered by shingle tabs in the course above them.

The two inner notches at the top of the shingle will aid in the alignment of the two inner low nailing area fasteners while the

two outer fasteners are placed 1" (25 mm) from each edge of the shingle.

Note: See Malarkey's *Shingle and Accessory Warranty* online for any additional requirements related to specific coverages. (See **Figure 9**)

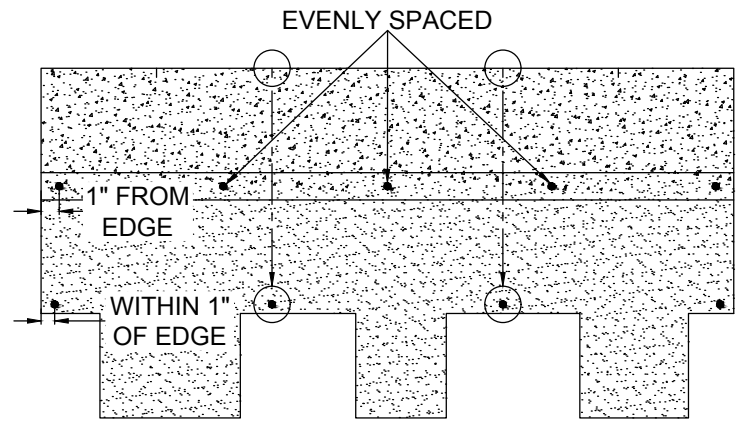

Figure 9 - 9-Nail Fastening Pattern

*Windsor® shingles have five (5) notches on the top of each shingle. The two outer notches are $6\frac{3}{8}$ " (162 mm) from each edge, the two inner notches are each $12\frac{3}{4}$ " (324 mm) from the edge, and the center notch is at the middle of the shingle, $19\frac{1}{8}$ " (486 mm) from the edges.

When it comes to applying the shingles (see the *Shingle Pattern Layout* section below), the outer notches will play an important role for determining offsets and establishing a consistent diagonal pattern of shingles against the rake.

SHINGLE PATTERN LAYOUT AND APPLICATION

Important: The diagonal application procedures described below are necessary to prevent objectionable patterning. Malarkey is not responsible for such patterning on roofs where this diagonal application is not used. Exposures should be even along the courses as well, or an objectionable appearance may occur.

Malarkey Smart Start® Starter Shingles: Smart Start® starter shingles are designed to be separated lengthwise at a perforation so you get two, full-size starter shingles in one. The perforation is in the middle of the shingle, $8\frac{3}{16}$ " (208 mm) from each edge, and both pieces have seal-down strips. Besides eaves, it is recommended Smart Start® starter shingles be installed on the rake edges of roof to provide a clean edge and increase wind resistance.

6 $\frac{3}{8}$ " (162 MM) OFFSET - FOUR COURSE DIAGONAL METHOD

Starter Course: Install Malarkey Smart Start® starter shingles or equivalent conforming to ASTM D3462. Ensure they are positioned with the factory-applied sealant strip face up and the strip adjacent to the eave edge of the roof.

Lay the initial, full-length starter shingle on a lower corner of the roof, overhanging the rake and eave edges by $\frac{1}{4}$ " to $\frac{3}{4}$ " (6 - 19 mm).

Fasten with 4 nails, $1\frac{1}{2}$ " - 3" (38-76 mm) up from the eave, with one fastener 1" (25 mm) from each side of the starter and the remaining two evenly spaced on the same line as the end fasteners. Do not place fasteners in the seal-down strip.

Continue across the roof, butting the starter shingles loosely together and fastening in place.

Windsor® Starter Course: Trim one end of the first Windsor® Starter shingle, 6 $\frac{3}{8}$ " (162 mm), and lay it over the Smart Start® starter at the rake, positioning the Windsor® Starter so the full color blend overhangs the Smart Start® starter by approximately $\frac{1}{8}$ " (3 mm).

Fasten with four (4) nails in-between the paint lines, approximately 1" (25 mm) from each side of the starter and the remaining two evenly spaced. Continue across the roof, butting the shingles loosely together to prevent buckling, and fastening in place.

First Course of Shingles: Start with a full-length shingle and apply directly over and flush with the edges of the Windsor® Starter course on both eave and rake sides, maintaining the $\frac{1}{8}$ " (3 mm) overhang previously established. Secure with fasteners.

Second Course: Cut 6 $\frac{3}{8}$ " (162 mm) from one end of the first shingle and apply the remaining 31 $\frac{7}{8}$ " (810 mm) section over the underlying first course shingle and flush with the rake edge.

The bottom edge of the shingle tabs should line up with the top edge of the cutouts in the underlying shingle, leaving an exposure of 5 $\frac{3}{4}$ " (146 mm). Secure with fasteners.

Another way to position it is to align the right side with the right outside *notch* in the underlying *first* course shingle.

Third Course: Cut 12 $\frac{3}{4}$ " (324 mm) from the rake end of a full shingle and apply the remaining 25 $\frac{1}{2}$ " (648 mm) section over the underlying second course shingle and flush with the rake edge.

Position as before, lining up the bottom edge of the shingle tabs with the top edge of the cutouts in the underlying shingle, leaving an exposure of 5 $\frac{3}{4}$ " (146 mm). Secure with fasteners.

Another way to position it is to align the right side with the right outside *notch* in the underlying *second* course shingle.

Fourth Course: Cut 19 $\frac{1}{8}$ " (486 mm) from the rake edge of a full shingle (in half), and apply the remaining 19 $\frac{1}{8}$ " (486 mm) over the underlying third course shingle and flush with the rake edge. Position it carefully, allowing an exposure of 5 $\frac{3}{4}$ " (146 mm), and secure with fasteners.

Another way to position it is to align the right side with the right outside notch in the underlying *third* course shingle.

(See Figure 10)

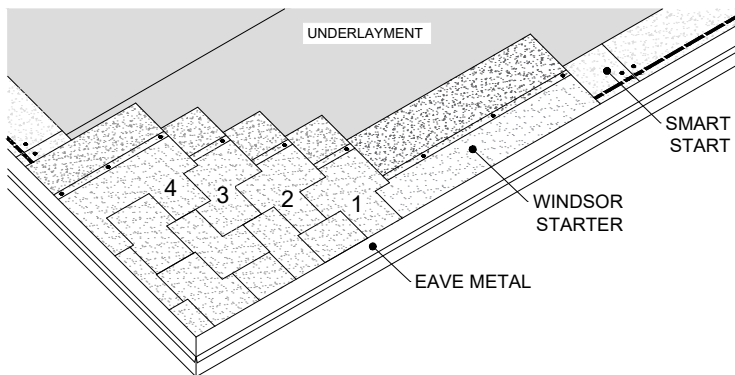

Figure 10 - Windsor® Shingle Layout Pattern with Smart Start® and Windsor® Starter Shingles

Prior to proceeding with the fifth course, fill in the preceding courses with full length shingles adjacent to the first pieces, and secure with fasteners. When fastening, butt ends loosely together to prevent buckling.

Courses Five and Above: To continue the installation on up the roof, repeat the diagonal pattern established in courses one to four. Snap a horizontal chalk line every six courses or so to ensure horizontal alignment.

Shingles may be laid from either lower corner of roof; follow layout and cutting instructions as required for proper application. If starting from the right rake, position the left side of cut shingles with the left outside notch in shingles of underlying courses.

Pieces cut from Windsor® shingles along the left rake can be used to finish off courses at the right rake. Because of our Windsor® shingles' unique tab patterning, they cannot be used to continue the diagonal installation pattern up the left rake.

Note: Straight up application of shingles, or *racking*, is not recommended.

CONSTRUCTING ROOF VALLEYS

Similar to a roof deck being prepared for shingles by first applying an underlayment, roof valleys must be likewise prepared before they can be "constructed" with shingles.

Open metal valley applications are recommended for Windsor® shingles, but *closed-cut valleys* are also acceptable. Contact Malarkey Technical Services for more information.

Valley Underlayment: Center a full-width strip of self-adhering underlayment (or equivalent conforming to ASTM D1970) in the valley, and apply it directly to the roof deck. Ensure this *valley liner* is tight to the deck without bridging in the center of the valley.

Field underlayment can be woven across the valley liner and up the opposite side at least 12" (305 mm) or lapped over each side a minimum of 6" (152 mm). When fastening, be aware no fasteners are allowed within 6" (152 mm) of the valley centerline.

Open Metal Valley Construction: Metal valley flashing (valley metal) used with Malarkey shingles must be minimum 24" (610 mm) wide and 26 gauge. Preformed, "W"-shaped flashing is recommended.

Center the valley metal over the valley liner, press it into the break of the valley, and secure with fasteners no more than 1" (25 mm) from the outside edges at a spacing of 10" (254 mm) to 12" (305 mm) O.C.

Set overlapping ends of the valley metal in a continuous bead of sealant, achieving a lap of 4" (102 mm). **DO NOT FASTEN THE METAL LAP.**

For additional sealing, a continuous 6"-wide (152 mm) strip of self-adhering Arctic Seal® may be applied over the fasteners on each side of the valley metal.

Never use a shingle trimmed to less than 12" (305 mm) in length to finish a course running into a valley. If necessary, trim a tab off the adjacent shingle in the course to allow a longer portion to be used. Make sure each shingle extends far enough into the valley so in a future step, a shingle's full width (or height) will be trimmed back.

Nail no closer than 6" (152 mm) to the valley centerline.

Now, trim shingles a minimum of 2" (51 mm) back from the centerline, cut the ends diagonally to match the centerline angle, and crop the top of each shingle at a 1" (25 mm), 45 degree cut.

Embed the ends of the cut valley shingles in a continuous 3" (76 mm) wide bead of asphalt roof cement conforming to ASTM D4586, and press them into the adhesive. **(See Figure 11)**

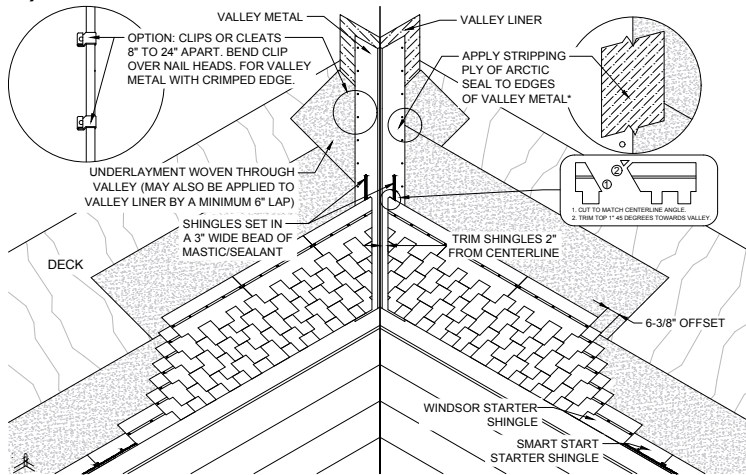

Figure 11 - Open Metal Valley Application

FLASHING APPLICATIONS

Intersections of Roof and Vertical Sidewall: Minimum 26-gauge, metal step flashing is used in the junction between a sloping roof and intersecting sidewall (on a dormer, for example) to protect this vulnerable area from moisture intrusion.

Step flashing can be square or rectangular, but 8-inch (203 mm) by 8-inch (203 mm) dimensions are common and satisfactory for our purposes.

Being 8" wide allows the flashing to be bent 90 degrees and pushed against the transition of roof to wall, the horizontal flange extending 4" (127 mm) out onto the roof deck and the vertical flange 4" (127 mm) up the wall assembly. Being 8" long allows individual step flashing pieces to overlap each other in water-shedding fashion as they are installed.

Individual step flashing pieces are integrated with each course of shingles as they are applied to intersect the sidewall. A 1/4" - 3/4" (6-19 mm) gap between the shingles and vertical bend of the flashing is recommended.

To allow for possible differential movement, fasten each piece of step flashing to the roof deck and not the sidewall.

Installation is as follows: Atop the Smart Start® starter course at the eave, place the first piece of step flashing*. The horizontal flange should be flush with the eave edge of the starter and the vertical flange against the sidewall, counter-flashed by the wall cladding.

Fasten the horizontal flange of the step flashing to the roof deck with two nails placed 1" (25 mm) from the upper edge and spaced an equal distance apart.

Apply the Windsor® Starter. The horizontal flange of the step flashing will no longer be visible, but you can still see the vertical flange along the sidewall.

Place the second step flashing atop the Windsor® Starter, and position it 5 3/4" (146 mm) up from the eave edge of the shingle, matching the shingle tab exposure, and fasten as before.

Position a first course Windsor® shingle over the Windsor® Starter and fasten.

Place the third step flashing atop that, overlapping the end of the previous step flashing by 2 1/4" (64 mm) - the point of shingle tab exposure.

Maintain the 5 3/4" (146 mm) exposure of each step flashing on up to the top of the sidewall intersection, alternating between the placement of step flashing and shingles.

* The "first piece of step flashing" in this instance might well be kickout flashing, a piece of flashing cut and angled to direct water out and away from the side of a structure.

To accommodate the angled part, yet still serve as the initial piece of step flashing, the kickout will likely have a greater length than a regular piece of step flashing. Otherwise, the installation of starter shingles, Windsor® shingles, and step flashing to follow is the same. **(See Figure 12)**

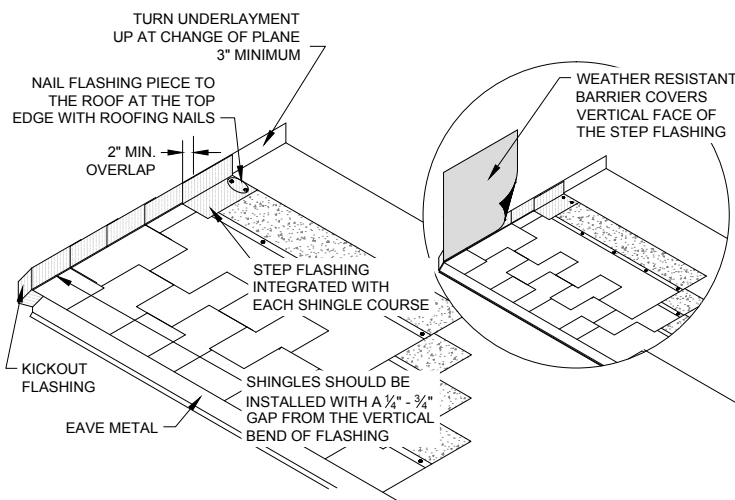

Figure 12 - Step Flashing Application at Roof-to-Sidewall Transitions

Vent Pipe (and Other Flanged Penetration) Flashing:

Install shingle courses up to the vent pipe, and cut a hole in the shingle to be positioned over the pipe. Install the pipe jack or boot (top and side flanges may be set in sealant).

Additional, *optional* weatherproofing: Unexposed pipe jack flanges (top and both sides) may also be stripped-off with minimum 6" (152 mm) wide Arctic Seal®, covering all fasteners used to secure the flanges, and tying onto the field underlayment a minimum of 3" (76 mm).

Continue roofing around the pipe, cutting shingles to fit on the sides and top of the pipe jack flanges. Ensure shingles extend beyond the downslope side of the pipe itself. Shingles that overlap any part of the flanges should be sealed to the flange with asphalt roof cement conforming to ASTM D4586. Correct amounts should not bleed out from under the shingles; excessive use may cause blistering. Apply pressure to seal.

(See Figure 13)

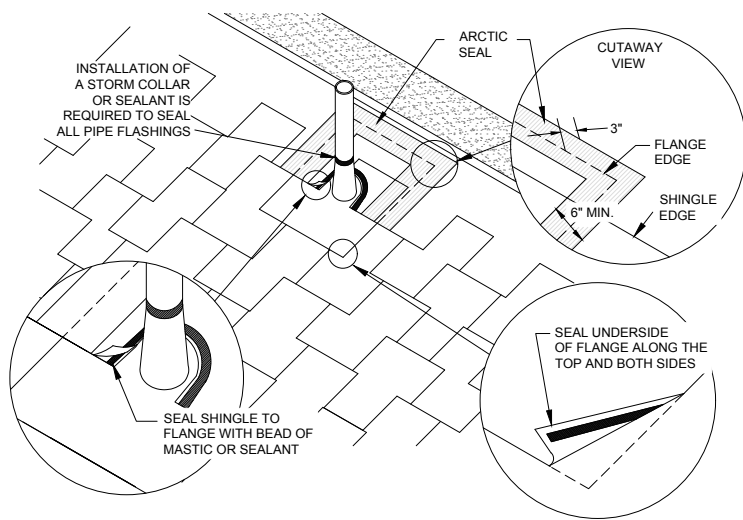

Figure 13 - Vent Pipe Flashing Application

Cap (Counter) and Chimney Flashings: The metal flashing apron for the front of the chimney shall be installed over the last course of shingles below the chimney and its vertical flange extending up the face of the chimney.

The metal flashings of chimneys, skylights, vents, and adjoining walls must be counter-flashed with sheet metal cap flashing.

Cap flashing (also called counter flashing) should originate in the masonry mortar joints of the chimney and be mortared-in or caulked with urethane sealant to ensure a watertight connection.

Cap flashing should then turn down the chimney and extend a minimum of 2" (51 mm) over the step flashings at all roof-to-sidewall intersections. (See Figure 14)

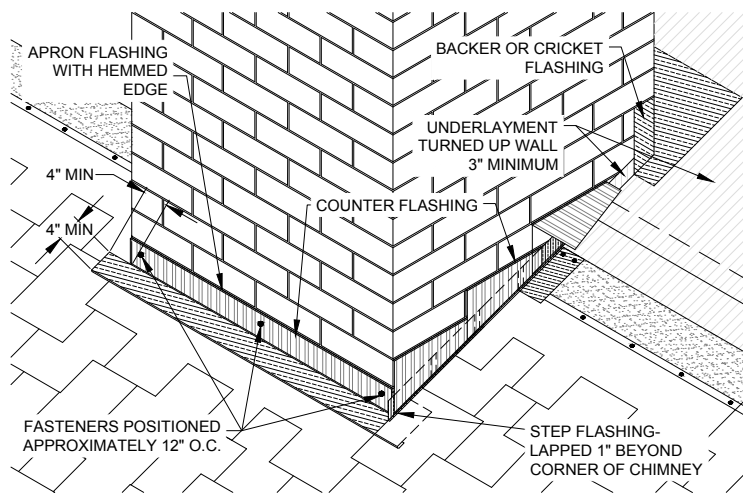

Figure 14 - Chimney Apron and Cap Flashing Applications

Chimney Saddles and Crickets: Apply Arctic Seal® self-adhering underlayment (or equivalent conforming to ASTM D1970) atop chimney saddles prior to the installation of flashing assemblies.

Flashing for chimney saddles and crickets shall be minimum 26-gauge galvanized or stainless steel, designed to cover the entire surface, and extend vertically 4" (102 mm) up the chimney.

Install a bead of mastic on the edges of chimney saddles and crickets. Press overlapping shingle courses into the mastic to seal. Seal all relief cuts and corners. (See Figure 15)

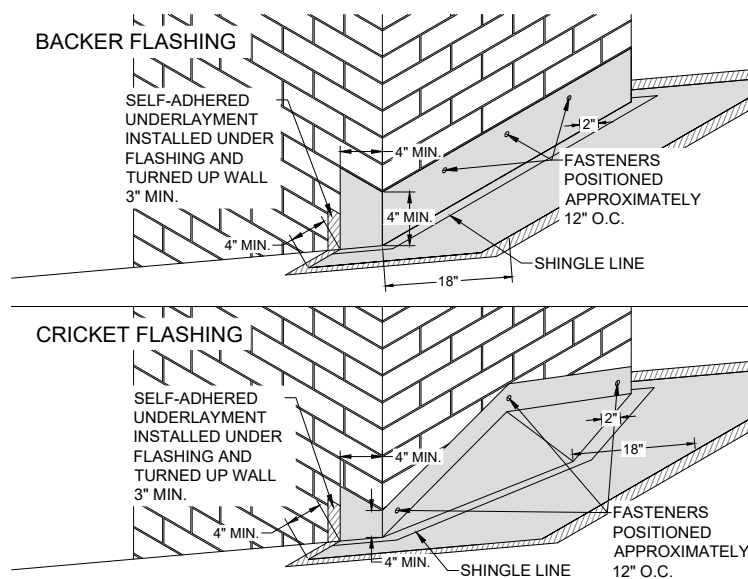

Figure 15 - Chimney Saddle and Cricket Flashing Applications

HIPS AND RIDGES

Malarkey EZ-Ridge® and EZ-Ridge XT® high-profile hip and ridge shingles are recommended for Windsor® shingles, but RidgeFlex® strip shingles may also be used. Some contractors adapt 3-tab roofing shingles to use as hip and ridge shingles, but Malarkey *only allows this when the field shingle is also a 3-tab shingle.*

Shingles featuring Scotchgard™ Protector from 3M (including Windsor® shingles) must be installed with hip and ridge shingles having Scotchgard™ Protector. All four of Malarkey's hip and ridge shingle types feature this algae-resistant protection.

Malarkey hip and ridge shingles also include a factory-applied, thermally activated seal-down adhesive that provides additional protection against blow-off. When applied in cold weather or a windy location, however, it is recommended each ridge shingle be hand-sealed under each lower corner with a quarter-size spot of asphalt roof cement conforming to ASTM D4586.

To avoid damage to hip and ridge shingles in cold weather, Malarkey recommends warming them sufficiently to prevent damage during installation.

LOW-PROFILE INSTALLATION (10" AND 12" RIDGEFLEX® HIP AND RIDGE SHINGLES)

Prepare for application by separating each hip and ridge shingle at the perforations: The 10" RidgeFlex® produces four (4) individual hip and ridge strips (see Figure 16), and the 12" RidgeFlex® produces three (3) (see Figure 17). Note the seal-down strips.

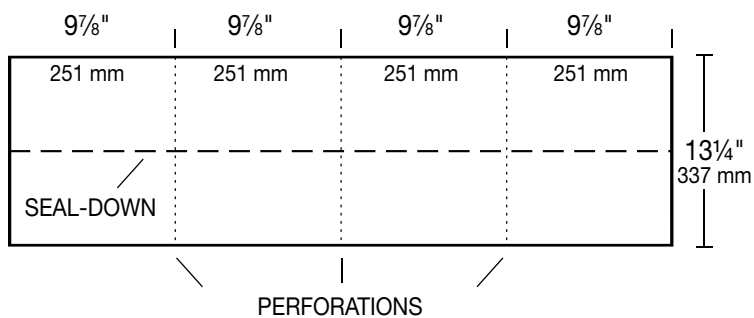

Figure 16 - 10" RidgeFlex® Hip and Ridge Shingle

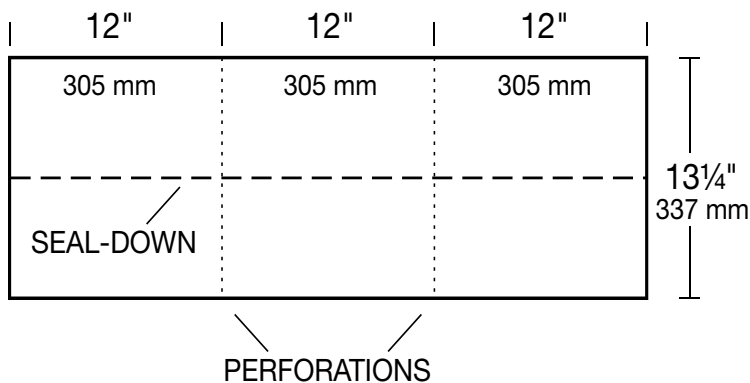

Figure 17 - 12" RidgeFlex® Hip and Ridge Shingle

Each scored strip is 13 1/4" (337 mm) tall and has an exposure of 5 5/8" (143 mm). You will be installing these individual pieces, and all are installed sealant side up.

Detail drawings to follow in this section show the installation of hip and ridge shingles along a roof ridge, but hips are essentially the same. Application begins at the bottom of the hip or from the end of the ridge opposite the direction of prevailing winds with a hip and ridge *starter shingle*.

RidgeFlex® Starter Shingle: Create a starter shingle by cutting off the 5 5/8" (143 mm) exposed portion of a RidgeFlex® shingle strip, and use the 7 5/8" (194 mm) remainder as a starter. (See Figure 18)

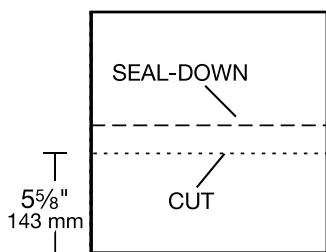

Figure 18 - RidgeFlex® Shingle Strip for Use as a Hip and Ridge Starter Shingle

Apply the starter shingle (with seal-down strip adjacent to the roof edge) over the bottom corner of the hip or on either end of the ridge, overhanging the corner or end by 1/4"- 3/4" (6-19 mm), and bending the starter shingle along its centerline to form into place (ensure shingles are sufficiently warm to avoid cracking).

Fasten with two nails, approximately 3" (76 mm) back from the leading edge and 1" (25 mm) up from each side. (See Figure 19)

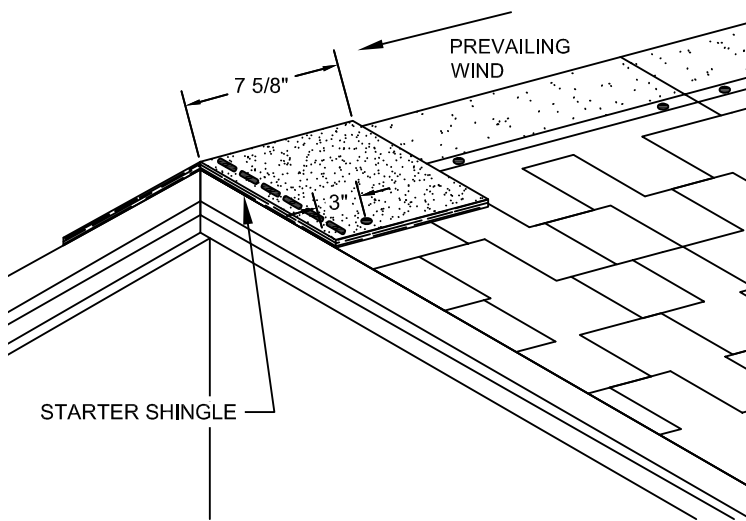

Figure 19 - Placement and Fastening of the RidgeFlex® Starter Shingle

RidgeFlex® Hip and Ridge Shingles: Lay the first RidgeFlex® shingle strip on top of the starter shingle (maintaining the overhang). Fasten with two nails, 1" (25 mm) more than the designed exposure and 1" (25 mm) up from each side so succeeding hip and ridge shingles conceal nailheads.

To aid installers for determining the *exposed* portion of a RidgeFlex® shingle, it's manufactured with a paint line in the headlap area, *opposite* the exposed portion. (See Figure 20)

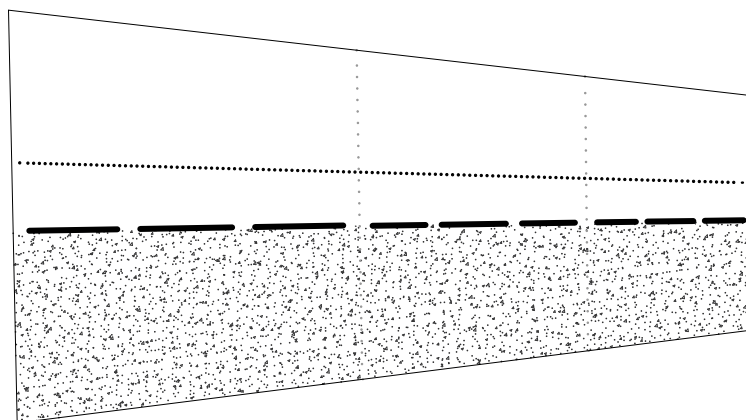

Figure 20 - Paint Line in Headlap Area of Shingle Is Opposite the Exposed Portion

Continue installing hip and ridge shingles, maintaining the exposure of 5 5/8" (143 mm) and fastening with one nail on each side and 1" (25 mm) up from the edge so succeeding shingles conceal nailheads. (See Figure 21)

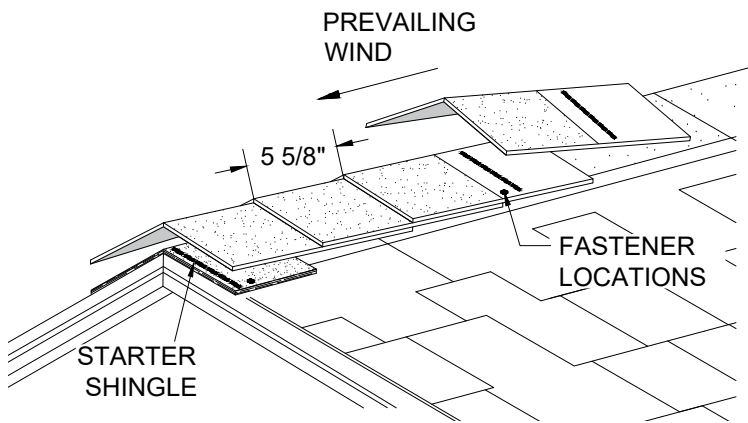

Figure 21 - Placement and Fastening of RidgeFlex® Shingles, Maintaining the 5 5/8" Exposure

At the end of the ridge, cut a shingle strip, and use the 5 5/8" (143 mm) exposed portion of a RidgeFlex® shingle to create an *end cap*. Position to maintain the exposure of 5 5/8" (143 mm), trim to fit, and set the cap in asphalt roof cement conforming to ASTM D4586. Press down firmly to seal. (See Figure 22)

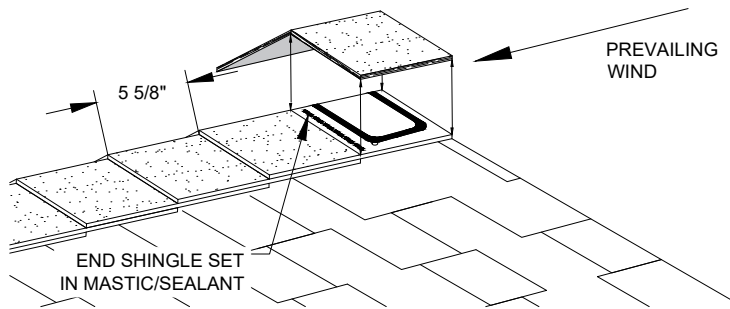

Figure 22 - Installation of RidgeFlex® Shingles; End Cap Set in Mastic

Should adverse conditions exist (like high winds), the end cap can also be face-nailed. Place two (2) nails on each side, 1" (25 mm) back from each end, and 1" (25 mm) up from the sides. Cover the nailheads with a dab of sealant.

HIGH-PROFILE INSTALLATION (EZ-RIDGE® AND EZ-RIDGE® XT HIP AND RIDGE SHINGLES)

Malarkey's EZ-Ridge® is a high-profile hip and ridge shingle specially designed to accompany laminate and Windsor® shingle applications.

Detail drawings to follow in this section show the installation of shingles along a roof ridge, but hips are essentially the same. Instructions for installing along rake edges are at the end of the section.

Given the added thickness of EZ-Ridge® shingles, ensure your fasteners are long enough to penetrate all layers and at least 3/4" (19 mm) into the roof sheathing. Where the roof sheathing is less than 3/4" (19 mm) thick, the fasteners shall penetrate through the sheathing.

Application begins at the bottom of the hip or from the end of the ridge opposite the direction of prevailing winds with a hip and ridge *starter shingle*.

EZ-Ridge® Starter Shingle: To create an EZ-Ridge® starter shingle, cut off the 8 1/4" (210 mm) *exposure* portion of the

shingle, and use the remaining 3 1/4" (83 mm) *cutout* portion (with sealant strip) as the starter. (See Figure 23)

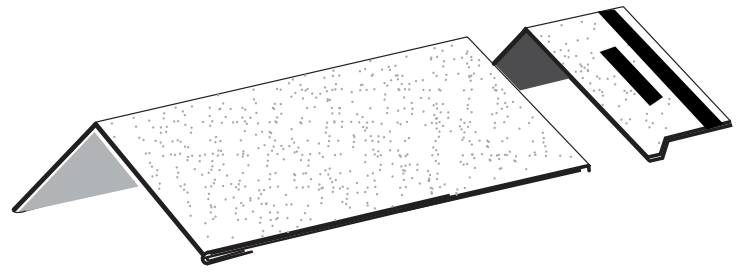

Figure 23 - Cutting an EZ-Ridge® Shingle to Make a Hip and Ridge Starter Shingle

Save the exposure portion because it can be used as the end cap on the opposite end of the ridge.

Note: The longer strip on the end of an EZ-Ridge® shingle is a film strip that prevents the shingles from sticking together while in the box they're packaged in. It is not designed to be removed.

Place the EZ-Ridge® starter shingle flush to the rake at the peak, and position it so the seal-down strip is adjacent to the roof edge. Push down on the center of the shingle and adjust to fit the pitch of roof.

Fasten with two (2) nails, one (1) on each side, 3/4" (19 mm) behind the cutout and 1/2" (13 mm) up from the side. If installed correctly, fasteners should be covered by the overlying EZ-Ridge® shingles to come, leaving none exposed.

EZ-Ridge® Hip and Ridge Shingles: Apply a full-size EZ-Ridge® shingle over the starter and overhang the end of the ridge by 1/4" - 3/4" (6-19 mm). Push down on the center of the shingle and adjust it to fit the pitch of roof.

Fasten this shingle and those to follow with two (2) nails, one (1) on each side, 3/4" (19 mm) behind the cutout (not on the exposed part of the shingle) and 1/2" (13 mm) up from the side.

Continue installing EZ-Ridge® shingles across the ridge, overlapping each with the side cutouts of the underlying shingle, and producing a consistent exposure of 8 1/4" (210 mm). Fasten in the same manner as the first. (See Figure 24)

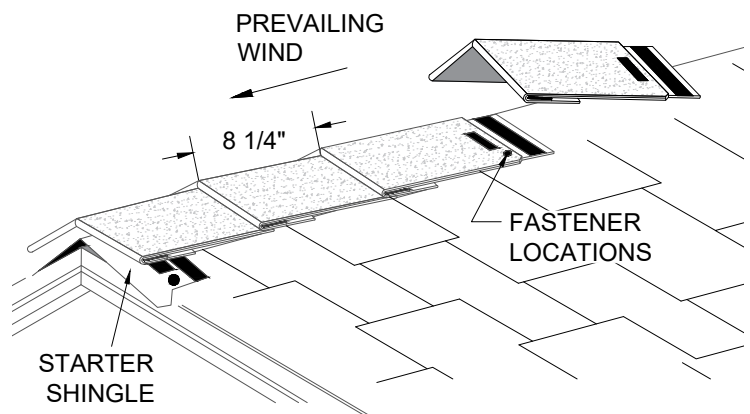

Figure 24 - Placement and Fastening of EZ-Ridge® Shingles, Maintaining the 8 1/4" Exposure

For the last hip and ridge shingle in the run, remove the cutout portion of an EZ-Ridge® shingle and trim the exposure portion to fit or use the exposure portion of the shingle you cut earlier when creating the starter.

Set this *end cap* in asphalt roof cement, maintaining the 8¼" (210 mm) exposure. (See **Figure 25**)

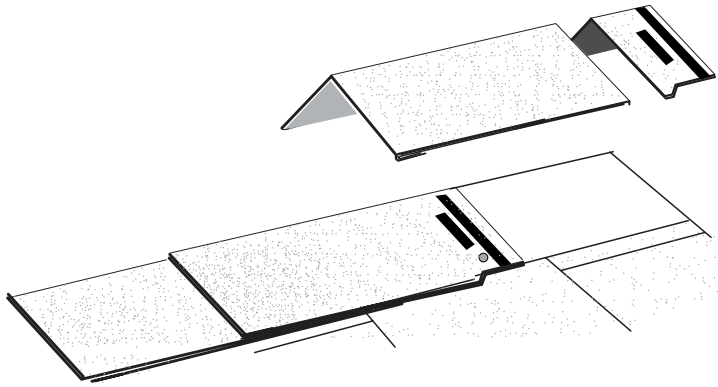

Figure 25 - EZ-Ridge® Shingle Cut to Create an End Cap

Should adverse conditions exist (like high winds), the end cap can also be face-nailed. Place two (2) nails on each side, 1" (25 mm) back from each end, and 1" (25 mm) up from the sides. Cover the nailheads with a dab of sealant.

Note: The end cap can also be flipped around to preserve the high-profile appearance and give a finished look to the ridge. Position it to overhang the end of the ridge by ¼" - ¾" (6-19 mm). (See **Figure 26**)

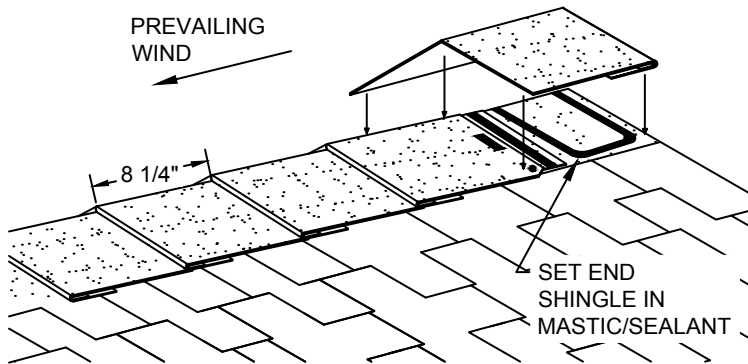

Figure 26 - Optional Positioning and Fastening of the EZ-Ridge® End Cap

EZ-RIDGE® RAKE EDGE INSTALLATION

Instructions are the same as those above with these exceptions:

1. Always start at the low end of the roof.
2. Have the high profile, finished end of EZ-Ridge® shingles in the lowest position.
3. Note: Installation with exposed nails may affect the aesthetic appeal of EZ-Ridge® shingles. (See **Figure 27**)

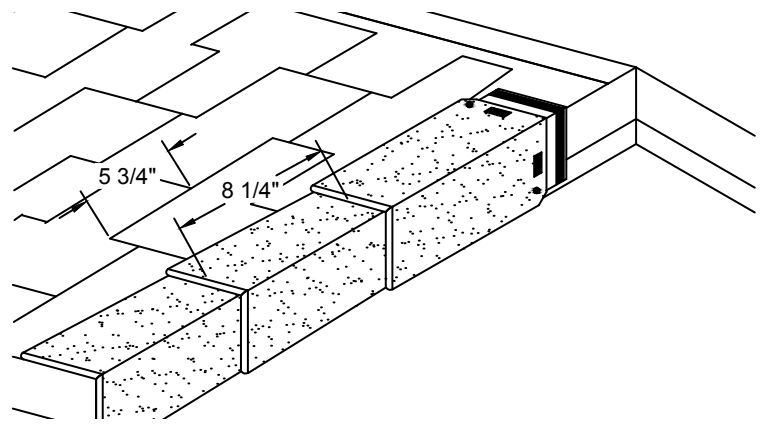

Figure 27 - Installation of EZ-Ridge® Shingles on Rake Edges of the Roof

RE-ROOFING OVER EXISTING ASPHALT SHINGLES

For best performance and appearance, it is recommended old roofing be completely removed from the deck.

When roofing over existing asphalt shingles, *it is recommended only 3-tab shingles be overlaid*. Roofing over laminates and designers like the Windsor® create an irregular surface across each course that may prevent the newly installed shingles from sealing down properly, leaving them more susceptible to wind damage.

In some areas, building codes do not require removal of old roofing if: 1) The existing shingles and framing will support the workers installing the roofing, the new roof itself, and required dead loads; and 2) The old wood deck is sound and able to provide good anchorage for nails.

Make the surface as smooth as possible by replacing missing shingles and securely nailing all buckles, raised tabs or curled shingles. Malarkey is not responsible for objectionable appearance of the new surface from any irregularity in the substrate caused by remaining roofing.

Additional ventilation should be provided, and longer nails will likely be necessary to penetrate a minimum of ¾" (19 mm) into the roof deck or completely through plywood or OSB sheathing.

Installing UL 2218 Class 3 or Class 4 impact resistant shingles over existing roofs negates their impact resistance and will not make them eligible for insurance discounts.

FINAL NOTE

These instructions are meant to act as a general guide. If you have questions about this installation or any Malarkey roofing product, please contact our Technical Services Department weekdays at (800) 545-1191 or (503) 283-1191, 7:00 am to 5:00 pm Pacific Time. You can also email us at malarkey.technicalinquiries@amrize.com. Thank you.



P.O. Box 17217
Portland, OR 97217-0217

Rev. 08/25