

ZEAFIVE[®]

Installation Guide

WALL MOUNT UTILITY SINK



PRODUCT
INSTRUCTION
VIDEO

MODEL No.ZHS-W2420

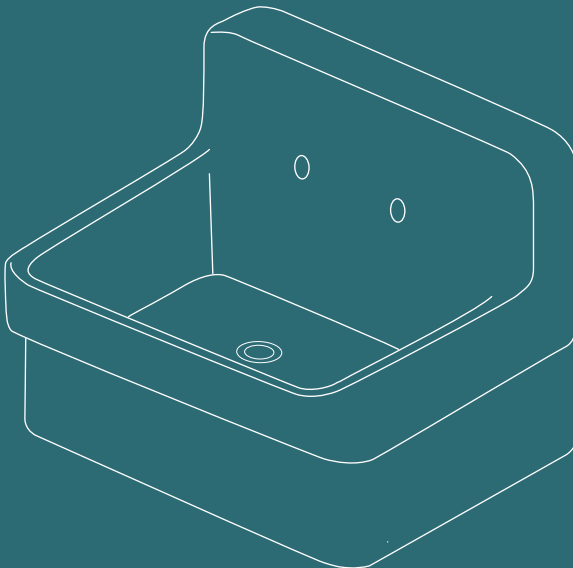

 Email: service@bestgosupplychaininc.com



Prior to Installation:

- Observe and comply with all building and plumbing codes.
- As our basins are handcrafted and dimensions are approximate, we recommend using the actual basin for the cutout.
- Use sink clips and 100% Silicone (non-water based) for installations.
- Ensure adequate space behind the basin for faucet and backsplash, including the full range of motion for faucet handles and spouts.
- Make sure a watertight seal exists on all drain connections.
- Do not place basin directly on floor. After unpacking, place basin on protective material such as packing materials.
- Remember to always use non-abrasive cleaners on ZEAFIVE sinks.

General Recommendations:

please read installation instructions thoroughly before installing the wall mount utility sink.

be sure to use proper tools and always wear proper personal safety accessories for your protection.

**If you have any questions or concerns
please contact us:**

 Email: service@bestgosupplychaininc.com

Tools and Materials



Tape Measure



Drill



Plumbers Putty



Putty Knife

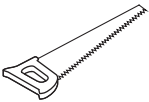

Hack Saw

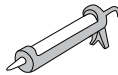

Silicone Adhesive



Screwdriver

Plus:

- (1) Pipe Wrench
- (2) Channel Lock
- (3) Tubing Cutter
- (4) Basin Wrench
- (5) Saber saw
- (6) Adjustable Wrench

NOTE

Additional tools might also be used to complete the installation.

Parts List:

- (1) Wall Mount Utility Sink x 1
- (2) Mounting Bracket x 2
- (3) Basket Strainer x 1

Sold Separately

- Wall-mount Faucet x 1
- Sewage Trap x 1

Prior to Installation



Read the following instructions thoroughly before installation of the sink:

- Observe all local plumbing and building codes.
- Shut off hot and cold water supplies. Inspect drain and supply tubing. Replace if necessary.
- Unpack new sink and inspect it for damage. Afterward, return the sink to its protective carton until the installation begins.
- Two persons are required to place and install the sink.
- The cabinet and frame shown in the illustrations are generic and intended as suggestions only. All illustrations in the following instructions assume installation with a standard countertop. Other countertop sizes may also be used.
- Use proper securing hardware and techniques to ensure the support frame will bear a minimum of 300 lbs (136kg).

Installation Procedures

Wall Mount Installation

Step I. Install Mounting Brackets

- Make sure the water supply is 8" apart for a two-hole faucet installation.
- The mounting brackets should be 11.4" to 11.8" apart. Mark the intended locations with a pencil. Check for levelness.
- Hold the brackets level and mark the locations for the screw holes on the wall. Install the mounting brackets to the wall and check again for levelness before fully tightening all screws into position.

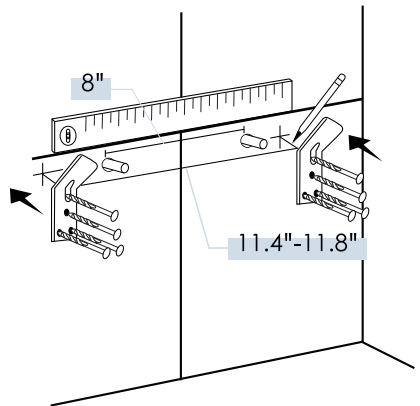

Step II. Install Sink

- Carefully lower the sink onto the bracket using the slot on the back of the item and check levelness. Make adjustments if necessary.

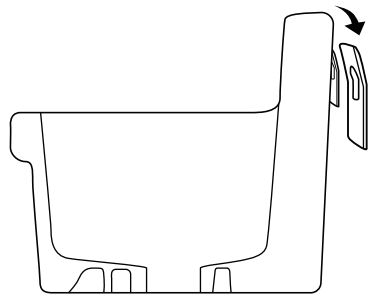

CAUTION Risk of personal injury or product damage. Get help lifting the sink.

- Install faucet and drain assembly according to the manufacturer's instructions.

Reminder Do not overtighten fittings as it might damage the chinaware.

c. Run water to test for leakage.

Top Mount Installation

- Before proceeding, determine your cabinet design:

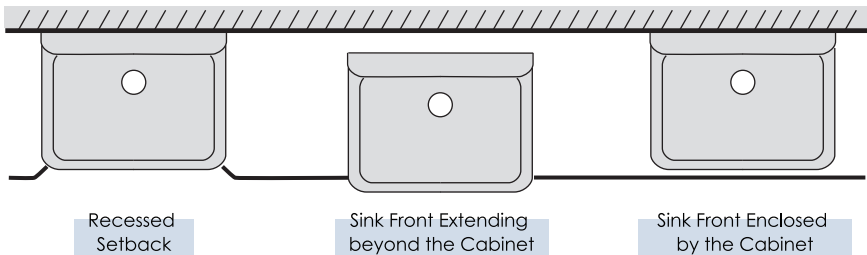

Step I. Construct Cabinet and Support Frame

a. Measure the actual size of sink below the rim flange.

NOTE The cabinet opening should equal the sink dimensions to ensure a minimum gap between the sink and the cabinet. If the sink is not available at the time of cabinet construction, make allowances to add wood filler strips to the opening after the cabinet is constructed and before the sink is installed.

b. Carefully measure and sketch the cut-out area according to the measurements taken from the actual sink. Cut the countertop and cabinet along the traced lines.

c. Construct a wood support frame inside the cabinet opening using 2x4 lumber and a 1/2" plywood, as shown in the illustration. Locate and cut the drain outlet clearance hole on the plywood.

NOTE Make sure the distance between the top of plywood and the top of countertop is identical to the distance between the bottom of the sink and the bottom of the sink rim.

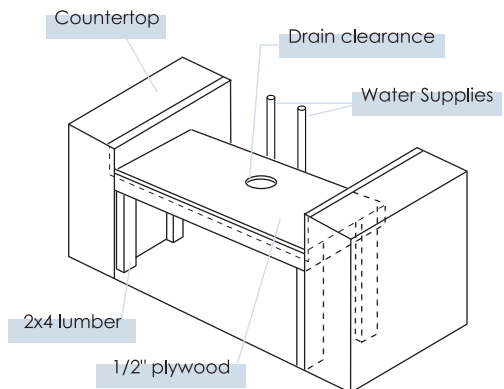

Step II. Install Sink

a. Temporarily place the sink onto the cabinet opening. Check for alignment and clearance, then trace around the outside edge of the sink as a guide for application of sealant. Then remove the sink.

b. Apply a masking tape 1/8" outside the traced outline of the sink and apply a generous portion of silicone sealant inside the traced lines on the countertop.

c. Carefully lower the sink into place, properly position it using guidelines on the countertop, and press down firmly.

d. Apply additional sealant if necessary to provide a uniform bead from the sink rim to the masking tape. Remove any excess sealant and then the masking tape.

e. Install water supply and drainage system according to the manufacturer's instructions.

Reminder Do not overtighten fittings as it might damage the chinaware.

f. Run water to test for leakage.

 **CAUTION** Risk of personal injury or product damage. Handle with care. Product can break, chip, cause injury or product damage if handled carelessly. Get help lifting the sink.

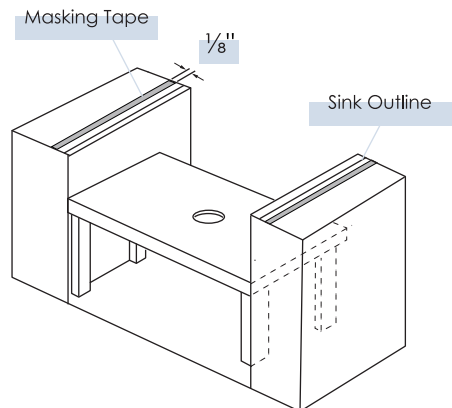
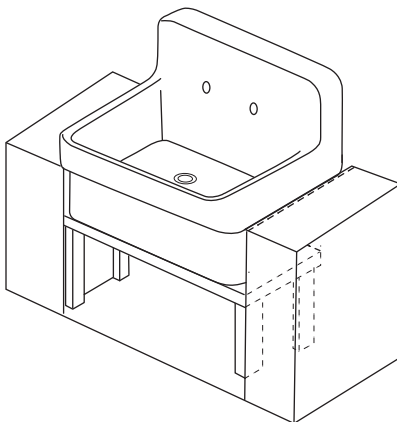

ZEAFFIVE Utility Sink are meticulously handcrafted with fine fireclay or ceramic and have undergone strict quality inspections. With proper care and cleaning measures, ZEAFFIVE sinks will keep in new condition and function well for an extended period of time.

General Cleaning



- It's recommended to clean ZEAFFIVE sinks on a regular basis to avoid the build-up of soap or mineral deposits.
- When cleaning, use a non-abrasive cleaner and a soft cloth to rinse the sink thoroughly and wipe it dry to eliminate water spots, as allowing water or cleaners to evaporate will have a negative effect on the appearance of the sink.

Do's



- ✓ Rinse laundry detergent thoroughly and make sure there's no residue.
- ✓ Wipe the sink dry using a soft cloth after each use.
- ✓ Scrape off any heavy grime with a plastic spatula.
- ✓ Use baking soda or mild detergent to clean off heavy stains.
- ✓ Test the cleaning solution on an inconspicuous area before applying it to the entire surface.
- ✓ Use a strainer to catch lint and small items like buttons to prevent clogging.



Strainer



Mild
Detergent



Plastic
Scraper

Don'ts



- ✗ Avoid storing open containers of household cleaners and chemicals containing chlorides such as bleach, acid, drain cleaners, or toilet bowl cleaner beneath the sink.
- ✗ Avoid using harsh, abrasive cleaners or chemicals as they will potentially scratch the surface.
- ✗ Avoid direct contact with sharp and metallic objects by using protective plastic bowls, rinse baskets, and sink grids with non-abrasive bases.
- ✗ Never use steel wool, cleaning pads, or any other form of abrasive cleaning materials to clean the sink as this may dull and damage the surface of the sink.
- ✗ Do not set hot pans or other hot items directly into the sink until they cool down.
- ✗ Do not leave any form of standing water in the sink, especially if the water contains anything that could stain the sink.

THREE YEAR LIMITED WARRANTY

LIMITED WARRANTY COVERAGE

3 YEAR LIMITED WARRANTY

ZEAFIVE products are made with quality materials and excellent craftsmanship to provide the customers a long-lasting product. In the case of any defects in materials or craftsmanship under regular use were inspected in the first one year of delivery, ZEAFIVE will provide replacement parts at no charge, or at its option, replace any product or part of the product that is deemed defective, under normal installation, use, service and maintenance. This warranty applies only to the original purchaser. Proof of purchase will be required in the case of a claim. SCRATCHES ARE NOT COVERED UNDER WARRANTY.

The manufacturer warrants this product to be free of manufacture defects during the above mentioned warranty time. Please keep a copy of the original invoice as proof of purchase.

ZEAFIVE will, as its option, (1) repair or replace the defective part(s) or product(s) at no charge; (2) issue a refund of the original purchase price of the product(s) (Valid within 30 days from the date of delivery); or (3) issue a credit to be applied toward the purchase of a new ZEAFIVE product shipping/delivery charges may apply and are in ZEAFIVE sole discretion.

OUR recommends the installations to be made by a licensed, professional plumber. ZEAFIVE will not be held responsible for any damage or product failure due to improper installation, misuse, or failure to use a licensed professional. OUR is not responsible for any removal or installation cost.

This limited warranty shall not apply to goods which have been subject to accident, negligence, improper installation, product abuse, product misuse, or use of cleaners containing abrasives, alcohol or other organic solvents, whether performed by a contractor, service company, or yourself, are excluded from this warranty.

ZEAFIVE responsibility under this limited warranty is limited to only to replacement parts and no other costs. ZEAFIVE will not be responsible for labor charges and/or damage incurred by installation, repair or replacement, nor for any indirect incidental or consequential damages, losses, injury or costs of any nature relating to this product except as provided by law, this limited warranty is in lieu of and excludes all other warranties, conditions, and guarantees, whether expressed or implied, statutory or otherwise, including without restriction those merchantability of fitness for use.

RESPONSIBILITIES OF OTHERS

Inspecting the unit prior to installation is the responsibility of the installer or building contractor who acts on behalf of the user. They are responsible for ensuring the unit is free of defect or damage.

Notices are placed on and in the unit and on the shipping carton advising the installer of this responsibility.

In the event of a problem, the unit must not be installed. ZEAFIVE is not responsible for failures or damage that could have been discovered, repaired, or avoided by proper inspection and testing prior to installation.

Damage occurring in transit is the responsibility of the carrier. The user or installer MUST open the crate and inspect the unit for damage when it is delivered. If damage is discovered, it must be reported immediately to the seller and the carrier in writing, and an inspection requested. Failure of the carrier to respond should be reported to the seller and the carrier. Your freight claims should be filed promptly thereafter.

LIMITATIONS AND EXCLUSIONS

This warranty does not cover instances of negligence, misuse, abuse, improper installation, carelessness, accident, hard water or mineral deposits, exposure to corrosive materials, misapplication, damages caused by improper maintenance, alteration of the product, or failure to follow care or installation instructions enclosed with your product. This warranty is void if the ZEAFIVE is subject to alteration, or if repairs are attempted by anyone other than an authorized agent of ZEAFIVE. This warranty does not extend to plumbing or components installed by dealers, installers or by any party other than ZEAFIVE.

ZEAFIVE will not be liable for loss of use of the ZEAFIVE inconvenience, or any other incidental or consequential costs, expense or damages. Please note that some states do not allow the exclusion or limitation of incidental damages.

DISCLAIMER

Except as expressly provided, there shall be no warranty or obligation, express or implied, oral or statutory. No dealer or other person has the authority to make any warranties or representations concerning ZEAFIVE or its products. In no event shall ZEAFIVE be held responsible for any such warranties or representations.

WARRANTY SERVICE

NOTE: When requesting warranty, be sure to have the following:

- Copy of original invoice
- Date of installation
- Description and pictures of defect
- Model number or description of model

To obtain warranty service and replacement part, please contact ZEAFIVE Customer Service. ZEAFIVE will determine whether to repair or replace your product, issue a refund, or issue a credit.