

GENUINE GRACO PARTS AND ACCESSORIES

Seal Repair Kit

for T2 2:1 Ratio Transfer Pump

247883 Lower Seal Kit



407005D

EN



Important Safety Instructions

Read all warnings and instructions in manual 311882.
Save those instructions.

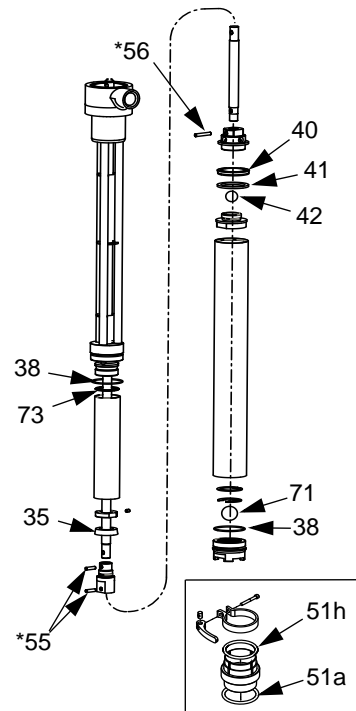

Ref Part	Description	Qty
35	15J562 PACKING, piston cup	1
38	106258 O-RING	2
40	15J565 PACKING, u-cup, PTFE	1
41	15J566 RING; wear	1
42	103462 BALL; outlet	1
51a	120998 O-RING; O.D.	1
51h	120207 O-RING; inner (brown)	1
55*	120294 PIN; straight, 3/16 x 3/4	2
56*	120295 PIN; straight, 3/16 x 1-1/4	1
71	107167 BALL; intake	1
73	113944 O-RING	1

* The spring pins (55, 56) originally supplied in Series A and B pumps have been upgraded to a solid clevis pin for improved reliability.

r_295616_407005_1a

51